



Why Not

Family	Armchair / Sofa / Bench / System
Designer	Luca Botto / 2010
Link	www.read-mo.re/why_not

IT Un ritmo fluido per il divano che tiene insieme rigore formale e libertà di composizione, per entrare con personalità in ambienti di qualsiasi dimensione. Le linee minimali esprimono purezza dello stile che può arricchirsi di leggerezza grazie a cuscini molto confortevoli.

EN The flowing rhythm of this sofa fuses formal exactitude and freedom of composition, allowing it to fill rooms of any size with its personality. The minimal lines embody the purity of its style, which can be lightened by extremely comfortable cushions.

FR Un rythme fluide pour le canapé qui conjugue rigueur formelle et liberté de composition, lui permettant de s'introduire avec personnalité dans les environnements de toutes tailles. Les lignes minimalistes expriment la pureté de son style qui peut devenir encore plus léger grâce à l'ajout de coussins ultra confortables.

DE Ein flüssiger Rhythmus für ein Sofa, das äußerliche Strenge und Freiheit der Komposition in sich vereint, um mit Persönlichkeit Räumlichkeiten jeder Größenordnung zu beherrschen. Die minimalen Linien drücken die Reinheit des Stiles aus, dem die äußerst komfortablen Kissen noch mehr Leichtigkeit verleihen.

WHY NOT cod. 8453 / 8458 / 8459
System /
ACCURSIO cod. 9042
Coffee table /
UP cod. 8506
Coffee table





WHY NOT

WHY NOT cod. 8456 Sx
Left element 190 /
WHY NOT cod. 8457 Dx
Right element 190 /
WHY NOT cod. 8455 Sx
Left half back element 190 /
UP cod. 8505 / 8506
Coffee table

Opposite page:
WHY NOT cod. 8456 Sx
Left element 190 /
WHY NOT cod. 8457 Dx
Right element 190



ARMCHAIR / SOFA / BENCH / SYSTEM



Dati tecnici · Technical data · Données techniques · Technische Angaben

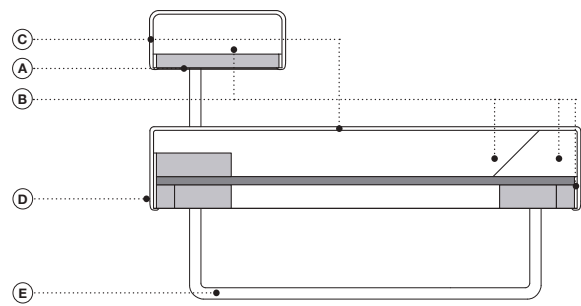

- | | | | |
|--|---|--|--|
| ■ Legno massiccio di faggio | ■ Solid beech | ■ Bois de hêtre massif | ■ Massivholz aus Buche |
| ■ Multistrato di faggio | ■ Multilayered beech | ■ Multiplis de hêtre | ■ Buchenschichtholz |
| A. Pannello di masonite | A. Masonite panels | A. Panneau de particules | A. Holzfaserplatte |
| B. Poliuretano espanso ignifugo indeformabile a quote differenziate | B. Flame-retardant undeformable polyurethane foam of different densities | B. Mousse polyuréthane expansé ignifuge indéformable à épaisseurs différenciées | B. Feuerfester formbeständige Polyurethanschaum in unterschiedlicher Dichte |
| C. Fibra di poliestere | C. Polyester fibers | C. Fibre de polyester | C. Polyester |
| D. Rivestimento | D. Upholstery | D. Revêtement | D. Bezug |
| E. Acciaio | E. Steel | E. Acier | E. Stahl |

Caratteristiche · Features · Caractéristiques · Eigenheiten

- | | | | |
|---|--|---|--|
| · Telaio rinforzato per uso aree pubbliche | · Reinforced frame for public area use | · Structure renforcée pour une utilisation en espace public | · Verstärkte Holzstruktur für Nutzung bei öffentlichem Bereich |
| · Poliuretano espanso ignifugo | · Flame-retardant polyurethane foam | · Mousse polyuréthane expansé ignifuge | · Feuerfester Polyurethanschaum |
| · Poliuretano espanso indeformabile a quote differenziate ad alta densità | · Undeformable polyurethane foam of different densities | · Mousse polyuréthane expansé indéformable à épaisseurs différenciées | · Formbeständige Polyurethanschaum in unterschiedlicher Dichte |
| · Cuciture rinforzate con supporto in fibra di carbonio | · Reinforced stitching with carbon fiber support | · Coutures renforcées de fibre de carbone | · Verstärkte Säume mit Stütz aus Kohlefaser |
| · Basi personalizzabili con colore su richiesta del cliente | · Bases customizable with other colors on customer's request | · Piètements disponibles en autres finitions sur demande | · Gestell in Kundenfarben auf Anfrage verfügbar |
| · Prodotto disponibile anche su misura | · This item can be customized | · Produit pouvant être réalisés sur mesure | · Produkt nach Maß verfügbar |

Coordinati · Matching items · Produits assortis · Abgestimmte Produkte



Finiture · Finishes · Finitions · Ausführungen



- | | |
|---|--|
| Cromato lucido
Polished chrome
Chromé brillant
Chrom poliert | Nero (RAL 9005)
Black (RAL 9005)
Noir (RAL 9005)
Schwarz (RAL 9005) |
|---|--|

cod. 8451 / 3 seater

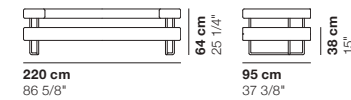

cod. 8452 / 4 seater

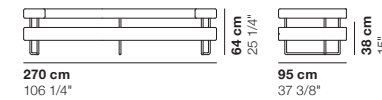

cod. 8469 / element 100

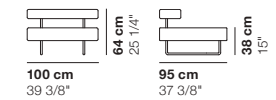

cod. 8470 / element 140

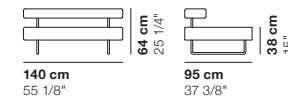

cod. 8453 / element 190

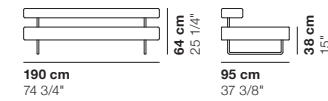

cod. 8454 dx / right half back element 190



cod. 8455 sx / left half back element 190

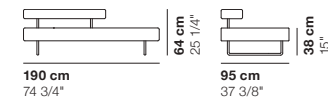

cod. 8456 sx / left element 190



cod. 8457 dx / right element 190

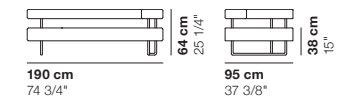

cod. 8458 / closed corner R 180

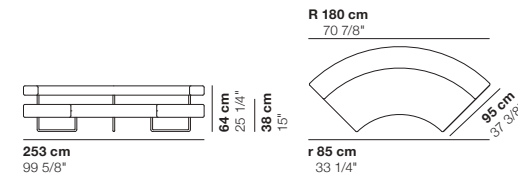

cod. 8459 / open corner R 180

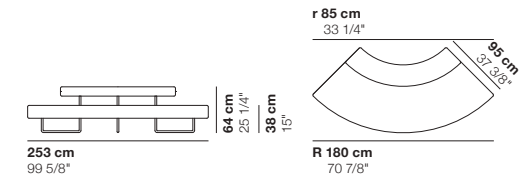

cod. 8460 / closed element R 395

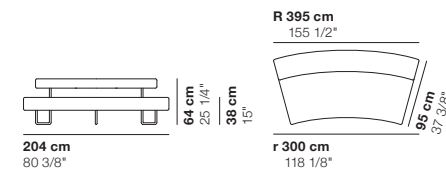

cod. 8461 / open element R 395

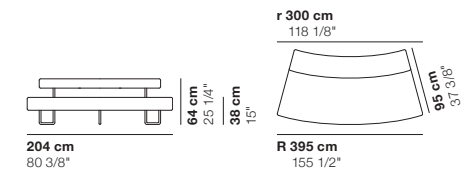

cod. 8464 dx / open element right half back R 395

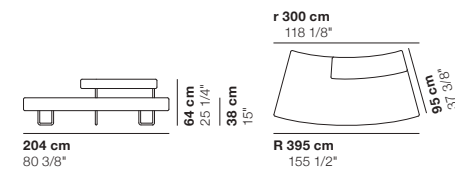

cod. 8465 sx / open element left half back R 395

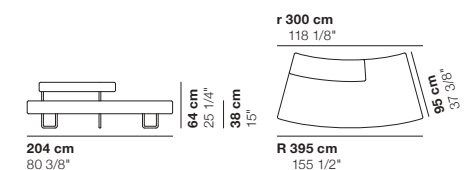

cod. 8463 dx / closed element right half back R 395

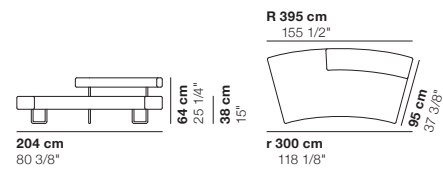

cod. 8462 sx / closed element left half back R 395

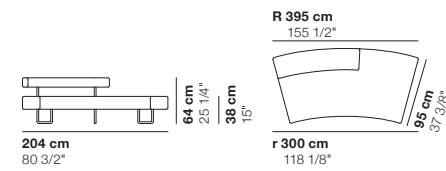

cod. 8466 / bench 190

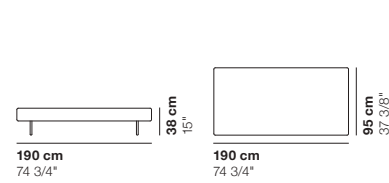

cod. 8467 / bench R 180

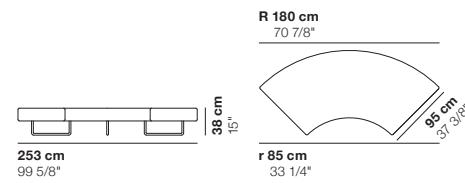

cod. 8468 / bench R 395

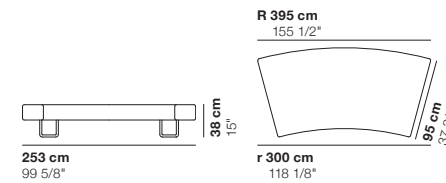

cod. WHY01 / composition

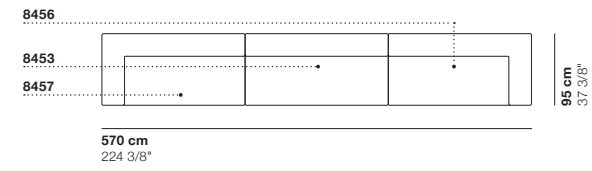

cod. WHY02 / composition

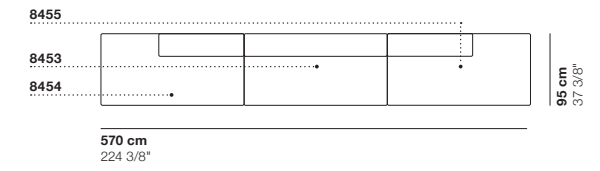

cod. WHY03 / composition

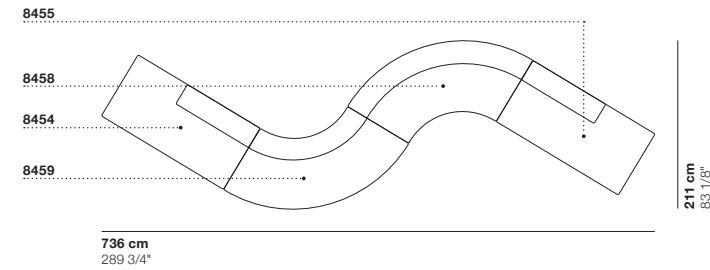

cod. WHY04 / composition

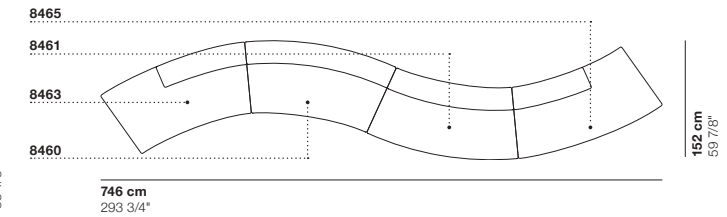

cod. WHY05 / composition

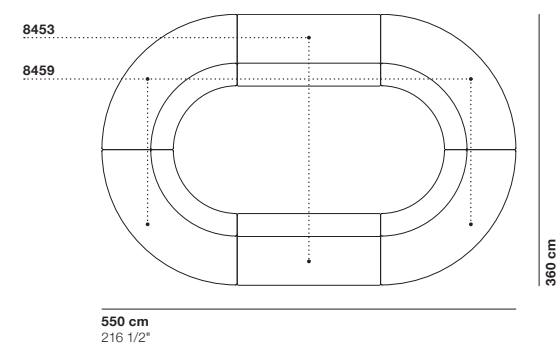

cod. WHY06 / composition

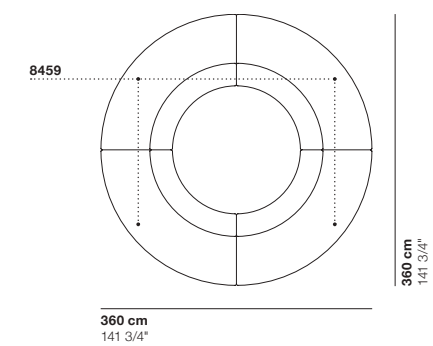

cod. WHY07 / composition

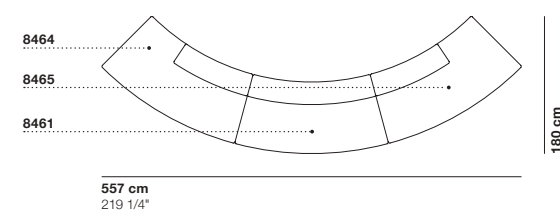

cod. WHY08 / composition

